

Item no. 2403



## User's Manual

# 8000W Power Inverter

By Wagan Tech

---

Thank you for purchasing this 8000 Watt DC to AC Power Inverter by Wagan Tech. With minimal care and proper treatment it will provide years of reliable service. Carefully read, understand and comply with all instructions before use. Keep this manual for future reference.

## CONTENTS

1. INTRODUCTION
  - 1.1. About This Inverter
  - 1.2. General Instructions
  - 1.3. Load Considerations
2. CONTROLS, INDICATORS AND CONNECTIONS
  - 2.1. Front Panel
  - 2.2. Rear Panel
3. OUTPUT WAVEFORM
4. PLANNING THE INVERTER SYSTEM
  - 4.1. Determining The Maximum Appliance Wattage
  - 4.2. Configuring The Battery Bank
  - 4.3. Derating The Battery Bank
  - 4.4. Fusing Requirements
5. CONNECTING THE INVERTER
  - 5.1. General Information
  - 5.2. Installation Procedure
6. CHARGING THE BATTERY BANK
  - 6.1. General Information
  - 6.2. Regular Loss Of Commercial Power
  - 6.3. Aboard a Vessel Or Vehicle
7. OPERATING ISSUES – TV and AUDIO
8. TROUBLESHOOTING
9. SPECIFICATIONS
10. DISPOSAL / RECYCLING
11. WARRANTY INFORMATION - REGISTRATION CARD

# 8000W Power Inverter

By Wagan Tech

## 1. INTRODUCTION

### 1.1 About this Inverter.

This power inverter converts 12 volts, direct current (12VDC) to 115 volts alternating household current (115VAC). It easily powers TV/VCR combinations, microwave ovens, refrigerators, even air conditioners! It also operates at highest efficiency (up to 90%) which results in longer running time and extended battery life compared to other inverters with this power.

This inverter has the highest surge capability in its class. Superior surge capability allows the inverter to start the most difficult motorized loads. Advanced, microprocessor-controlled circuits run cooler and, therefore, are more reliable than competing units.

### 1.2 General Instructions:

- Keep the Inverter away from any direct heat source or combustible materials.
- Keep well ventilated – this device generates heat.
- Keep the inverter away from combustible gases.
- Do not operate any equipment over 8000 Watts.
- This inverter will only operate from a 12- Volt DC power source.
- Do not attempt to connect the inverter to any other power source, including any AC power source.
- Incorrect battery polarity will damage the inverter and void the warranty.
- Keep this inverter in a dry environment.
- Do not open the inverter; there are no user serviceable parts inside.

### 1.3 Load Considerations

When a motorized appliance motor starts, it requires an initial surge of power. This surge of power is called the "starting load" or "peak load". Once started, the appliance requires less power to continue to operate. This is known as the "continuous load". It is important to know the starting loads and the continuous loads of the appliances that are to be powered by the inverter.

Appliance power is rated in watts. This information is usually stamped or printed on most appliances and equipment. In some cases, a tool will be rated in amperes. To convert from amps to watts, multiply:  $AMPS \times 115 \text{ (AC voltage)} = WATTS$ . This formula yields an approximation of the continuous wattage load of the appliance.

The start up load of an appliance is a major factor of whether this inverter can power it. Start-up load is momentary. With many devices, it is approximately twice the continuous load. However, with some devices start-up load can be as high as eight times the continuous load. To determine if an appliance or tool will operate with this inverter, run a test. This inverter is designed to automatically shut down in the event of an output overload, so there is no danger of damaging either the inverter or the equipment.

This inverter may not properly operate some devices with either speed control features or dimmer controls. Some appliance GFCI power cords will not operate properly while powered by this inverter. Again, the only way to be sure of proper operation, is to try it.

If an appliance within the 8000 watt range will not operate properly, it is likely that the inverter system does not have the required output to operate that appliance.

### SAFETY WARNING.

THE INVERTER OUTPUT CAN BE LETHAL. IMPROPER USE OF THIS INVERTER MAY RESULT IN PROPERTY DAMAGE, PERSONAL INJURY OR LOSS OF LIFE.

## 2. CONTROLS, INDICATORS AND CONNECTIONS

### 2.1 Front Panel

The Front Panel view shows the inverter's On/OFF Switch, indicators, AC outlets and direct wiring high current terminals.

# 8000W Power Inverter

By Wagan Tech

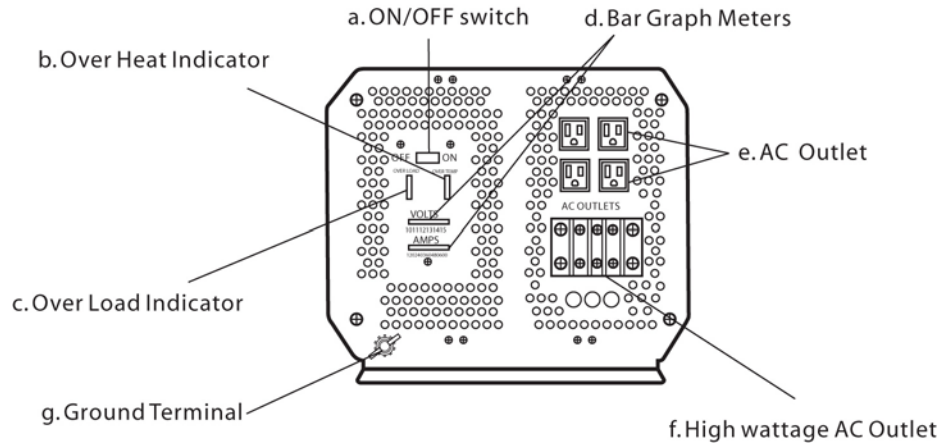

## a. ON/OFF Switch.

This switch controls ON/OFF operation of the inverter.

## b. OVER HEAT INDICATOR

The Over Temperature LED will turn RED and the inverter will automatically shut down if the inverter shuts down because of inadequate ventilation or excessive load. If this occurs, turn OFF the inverter and check that the ventilation openings are not blocked. Then check that the continuous power requirement of the appliance load does not exceed 8000 watts. After the shut down condition is removed, turn on the inverter. When the inverter cools to a safe temperature, it will automatically restart.

## c. OVER LOAD INDICATOR.

This indicator turns RED as the inverter shuts down. Immediately turn off some appliances if this occurs. The inverter will automatically restart.

## d. BAR GRAPH METERS.

The inverter is equipped with digital bar meters that display DC input voltage and DC current drawn to indicate system operation. These meters are there to assist

diagnosis if there are DC power supply problems.

DC voltage reading is the measurement of the voltage between the DC input terminals of the inverter, not the actual battery voltage. During high wattage applications the display may show a lower voltage level than the battery because of the voltage drop that occurs between the input cables and the battery. This voltage drop should not be excessive as this will seriously reduce run time. This inverter will operate with input voltage ranging from 11 to 15 Volts of direct current (DC). If the inverter input voltage level falls below 10.5 Volts DC, an audible alarm will sound. Should the voltage drop below 10 Volts DC, the inverter will automatically shut down.

During charging from a generator, solar panel, or AC powered charger, the battery voltage will be higher than when there is no load on the batteries. This inverter will shutdown if the input voltage is 15 Volts. It will shut down automatically if this occurs, however, in some rare cases voltages greater than 15 may cause damage to the inverter. Damage caused by excessive voltage input is not covered under warranty.

The DC Current Meter indicates the current drawn by the inverter with the present DC load operating. The current displayed is the sum of currents supplied to all the DC input terminals. The meter should show minimal current drawn when the inverter is operating and all AC loads are turned off.

## e. Four 115V AC Outlets.

Each outlet will supply 15A (1600 watts) 115V AC maximum, for powering appliances. Exceeding 15A of continuous power from an outlet may cause damage to the inverter and cause possible injury.

## f. High Wattage AC Outlet

There are three insulated terminals on the front panel of the inverter. These terminals are for connecting 115 Volt AC devices that require more than 15 amps to operate. Other uses are for connection to distributed wiring that has multiple AC outlets. Any wiring that is directly connected must be 6 gage or larger. Terminal connections from left to right are:

<b>LEFT</b>	<b>MIDDLE</b>	<b>RIGHT</b>
<b>GROUND</b>	<b>NEUTRAL</b>	<b>HOT</b>

**g. Ground Terminal.**

This connection is for connecting to a 6 gage insulated ground wire. Do not directly connect this ground connection to the Negative DC terminal. This is described in the installation procedure.

**2.2 Rear Panel**

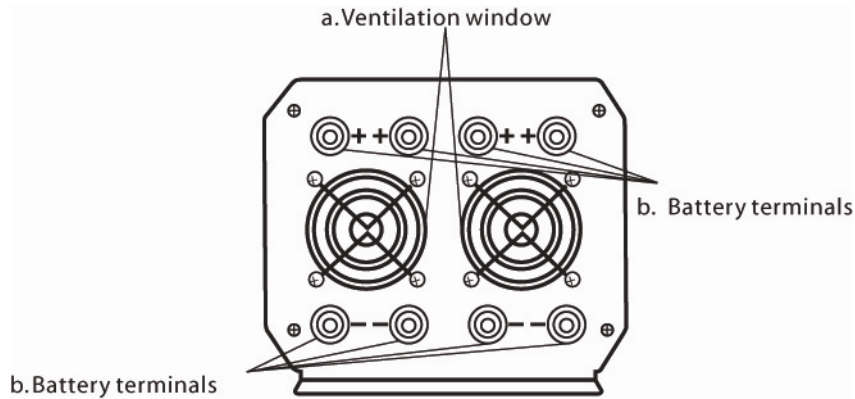

**a. High-Speed Cooling Fans/ Ventilation Windows**

The fans automatically operate when the internal temperature of the inverter requires cooling. Always allow free air flow – do not block the vents.

**b. Four Positive (+) DC Input Terminals, Four Negative DC (-) Input Terminals.**

All Negative (-) and Positive (+) DC terminals should be kept insulated to protect

# 8000W Power Inverter

By Wagan Tech

from accidental short circuits. Cable “boot” insulators are supplied that will cover the cable and terminal. If any positive (+) DC terminals are not used they should also be kept covered. All Positive DC terminals are connected together inside the inverter. All Negative DC terminals are connected together inside the inverter and connected to the chassis. It does not matter which Positive DC terminals are used. Similarly any negative DC terminal can be used.

Multiple DC terminal sets allow one to four sets of battery cables to be connected to the inverter. This allows multiple, more readily available flexible cables to be attached to the inverter.

**3.0 POWER INVERTER OUTPUT WAVEFORM**

This inverter’s AC output is a Modified Sine Wave (MSW) 115 volts AC. The comparison of Modified Sine Wave and household sine wave is shown below.

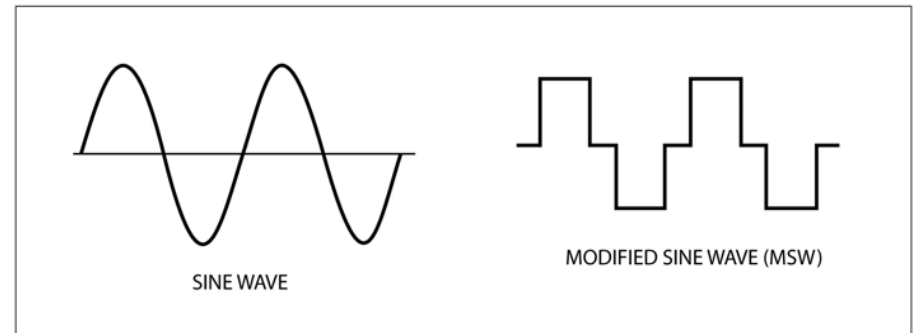

This modified sine wave has a root mean square (RMS) voltage of 115 Volts. Most ordinary AC voltmeters are calibrated to read “average” voltage and assume that the AC waveform will be a pure sine wave. These meters will not correctly read MSW voltage, and will display about 20 to 30 volts too low. Any multi-meter identified as "TRUE RMS" will accurately read MSW correctly.

# 8000W Power Inverter

## By Wagan Tech

### 5. PLANNING THE INVERTER SYSTEM

Larger wattage inverters require planning before installation. There are several steps to the planning process. The user must determine the following:

1. Maximum inverter wattage required
2. Operating time (run time) needed between battery recharges
3. Battery bank capacity in amp-hours
4. Charger requirement to recharge batteries within a reasonable time.

#### 5.1 Determining The Maximum Appliance Wattage

Maximum Appliance Wattage is the first factor in planning battery and charging systems.

Some background:

Large microwave oven specifications list cooking power (watts) and appliance power. Appliance power is the AC load the inverter has to supply.

Most other electrical tools, appliances and audio/video equipment have labels that list the unit's power requirements in watts. If the tool or device is rated in amps, multiply the amps by 115 (115-VAC) to determine the watts. For example, a power tool rated at 4-amps will draw 460 watts.

Determine the wattage of each appliance you need to simultaneously operate. Add all of the appliance wattages to obtain an estimated "total watts" number.

Remember to consider the start-up surge that motorized appliances will cause. Do not exceed the surge rating of the inverter.

At 8000 watts continuous output this inverter requires a DC power supply (battery bank) that can continuously supply 800 amps at 12VDC for the duration of the run time.

#### 5.2 Configuring the Battery Bank

To determine the minimum battery ampere-hour rating that you will need to operate appliances from the inverter, and any DC appliances powered by the battery bank. Follow these steps:

1. List the maximum wattage that the inverter has to provide (as above).

2. Estimate the number of hours the appliances will be in use between battery recharges. This will vary depending on appliances. For example, a typical home-use coffeemaker draws 500 watts during its brew time of 5 minutes, it maintains the temperature of the pot at about 100 watts. Typical use of a microwave oven is only for a few minutes. Some longer operating time appliances are lamps, TV's, computers and refrigerator/freezers.

3. Determine the total watt-hours of energy needed. This is done by multiplying the average power consumption in watts by the number of hours of run time. For example: 1500 watts for 10 hours = 15,000 watt hours.

To get an estimate of the maximum current (in amps) that a battery bank must be capable of delivering to the inverter, divide the load watts by ten. For example a 1500 watt appliance load will need 150 amps at 12 Volts DC.

Using the 1500 watts (or 150 Amps) for 10 hours example as above, then 150 amps is needed for 10 hours. This provides us with the basic amp-hours (AH) of battery that is required. Ten hours at 150 amps equals 1500 Amp Hours (AH). This answer is just a beginning because there are other factors that determine actual run time. These include:

- AC appliance load and time in use (basic AH)
- Cable gage and length (cable losses)
- Charge level of the batteries (between use, chargers have to be able to fully charge the batteries)
- Temperature of the batteries (colder batteries provide fewer amps)
- Age and condition of the batteries (older batteries lose capacity)
- Compliance with turning off unnecessary AC loads.
- Compliance with turning off unnecessary DC loads.

#### 5.3 Derating the Battery Bank

Most lead-acid batteries have a rating expressed in amp-hours (AH). The most common rating of AH is "at the 20 hour rate". For example; if a 20AH battery is discharged at a 1 amp rate, it will take 20 hours to discharge that battery. The terms "charged" and "discharged" relate to actual battery voltage. This means that the output voltage of a nominal 12 volt battery starts at 13.2 volts (fully charged) then drops to 10.6 volts (discharged). If the load on the battery causes the battery



to discharge faster than the 20 hour rate, the capacity (AH) of the battery is measurably reduced (derated). Derating is a major run time factor. The curve below can help to determine what the battery bank can deliver under load. The results are used to estimate how much additional battery capacity is needed to achieve the desired run time.

The left vertical numbers of the curve represents percentage of the battery capacity at the 20 hour rate. In this example, the user needs a one hour run time. If the example battery is 220AH (20hr rate), and the load is 220 amps that is 100 percent (horizontal number) of the AH (20hr rate). Starting at the 100 percent horizontal point and looking up to the curve the results are that only 56 the percent of the battery capacity is available. This means that a higher battery capacity is required to get the desired run time, one hour. The curve also shows that a load of 200 percent of the 20 hour rate yields only 31 percent of the battery capacity. The installer must carefully plan the capacity of battery bank or the run time may be seriously affected. To the inexperienced installer, several trial battery capacities may be required to make sure the large enough battery capacity is available to achieve the desired run time.

The curve can be applied to any lead acid battery under load providing that it has an AH rating at the 20 hour rate.

### Derating Curve Lead Acid Batteries

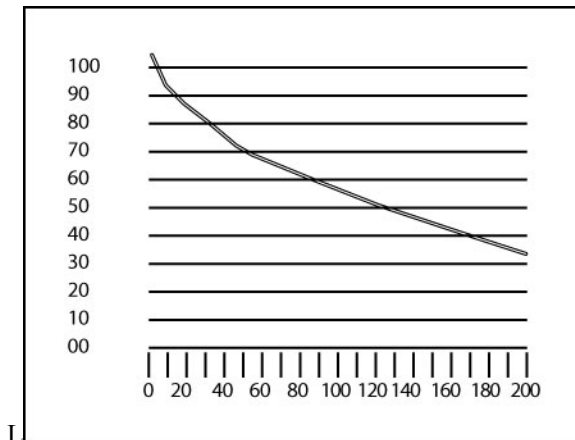

## 8000W Power Inverter

By Wagan Tech

Continuing with the example above: The 150 amp load will need to run for 10 hours, so we begin configuration with a 1500 AH battery. If the vertical is 1500 and the horizontal is 150 amps the percentage of load on the battery is 10 percent. The curve shows that the 1500 AH is derated to 90 % of maximum. This means that the battery will have to be 16500 AH for the full 10 hour run time. It is important to add some extra battery capacity, to compensate for battery age.

### CONFIGURATING THE BATTERY BANK

Six volt, 220 AH deep cycle “golf cart” batteries were selected for these illustrations because they are generally readily available and relatively inexpensive. With regular recharging they have a relatively long life. These batteries are “flooded” and vented types; they freely vent hydrogen and oxygen while under charging and heavy discharge. They must be vented to outside air to prevent accumulation of explosive gases.

If the batteries are to share a compartment with the inverter, then use sealed lead-acid batteries that are available in gel cell and AGM varieties. Both sealed battery types will not spill liquid electrolyte (acid) when overturned or punctured.

### Battery Bank diagram

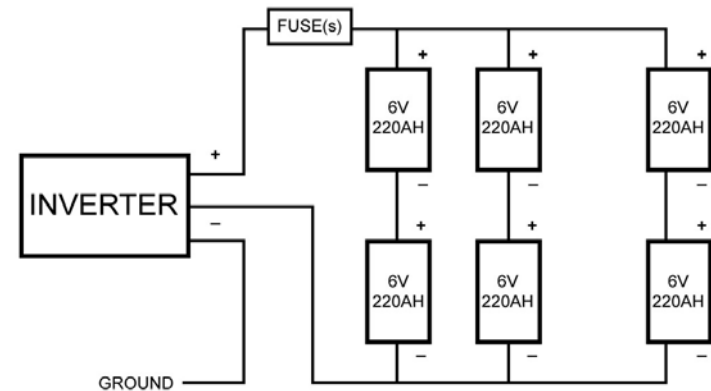

# 8000W Power Inverter

By Wagan Tech

## 5.4 Fusing requirements

NOTE: It is important that for this 8000 watt inverter has main battery fuses connected to the positive (+) battery cable(s) as close as possible to the connected battery bank's positive terminal. The fuse amperage rating must be sized to allow simultaneous operation of all the AC appliances to be powered, allowing for the momentary high start-up current requirements of inductive loads. Use the recommended fuse block (fuse holder) and fuse, or an electrical equivalent. ANL type fuses and fuse holders are readily available from marine supply dealers. The fuse and fuse holders may be connected in parallel to provide the required protection. There are larger capacity fuses and fuse holders available. Make sure that if the inverter is operating at 8000 watts that the battery is fused at greater than 800 amps.

The fuses are very important to protect equipment, batteries and personnel. The fuses protect against battery explosion if the cables that connect to the inverter accidentally short. READ AND COMPLY WITH THE WARNING BELOW.

**WARNING**  
**EXPLODING BATTERIES CAN SPRAY MOLTEN LEAD, HOT SULFURIC ACID AND OTHER METAL AND PLASTIC FRAGMENTS. BATTERIES THAT ARE CHARGING OR UNDER HIGH DISCHARGE RATES PRODUCE EXPLOSIVE HYDROGEN GAS INTO THE SURROUNDING AREA. BE SAFE - FUSE THE BATTERY BANK AND MAKE SURE THE BATTERIES ARE PROPERLY VENTILATED.**

### DC Cable Gage

Minimize cable losses by using the thickest wire available, and the shortest practical length. If the inverter and the battery are positioned within four feet of each other, a minimum of 0 gage (zero gage) insulated copper wire should be used to make the connections. If the distance is longer than 4 feet, heavier wire will be required.

Because multiple battery cables are used with this inverter, keep cable gages and lengths the same. This will ensure that cable losses will be evenly distributed. Use the following table as a guide to the number of cable connections required. Be sure to include any surge wattage in determining the cable configurations. Remember that terminals also have current carrying limits.

Total AC Watts	Negative cables (-)	Positive Cables(+)
2500 or lower	One	One
2500 or more but less than 5000	Two	Two
5000 to 8000	Four	Four

## 6. CONNECTING THE INVERTER

### 6.1 General information

Loose connections will result in a severe voltage drop that can cause damage to the conductors and insulation and cause sparking. Reverse polarity connection will blow the fuses in the inverter and can cause permanent damage to the inverter. Damage caused by reverse polarity will void the warranty.

### 6.2 Procedure

- 1 Make sure the cables are the proper gage and have the fuse holders as close to the battery bank's Pos (+) terminal.
2. Install the fuses in the Pos (+) cable.
3. Make sure the ON/OFF switch located on the front panel of the inverter is in the OFF (0) position. Disconnect any remote switch from the connector on the front panel.
4. Locate the Ground Lug Terminal at the rear of the inverter. Connect an insulated 6 gage copper wire to the terminal. The other end of the ground wire is connected to a "proper" grounding point. Use the shortest practical length of wire. Connect this wire to the chassis of your vehicle or to the grounding system in your boat. In a city, the ground wire can connect to a metal cold water pipe that goes underground. In remote locations, the ground wire can be connected to an "earth ground". This can be an attachment to a six foot long copper clad metal rod driven into the ground. In the unlikely event of a short circuit, operating the inverter without proper grounding can result in electrical shock. At the factory, the negative DC terminals are also electrically connected to the ground terminal.

5. Locate the cable/terminal insulating boots. Slide the boot on the cable before stripping the insulator and installing the ring connector.

#### NOTE

Ring connectors are required to fasten cables to the inverter's Positive and Negative DC terminals. The cable ends need to be stripped of insulation for approximately three-quarters of an inch before the ring terminals are attached. Be sure that the cable connector covers are on the cable so they can be reinstalled after the cables are connected.

6. Use a hex head wrench to loosen and remove the retaining nut on the terminal. Insert the Negative cable ring terminal on the threaded bolt of the terminal. Replace the retaining nut and tighten using the wrench. Make sure you have a good, secure connection.

7. Recheck and make sure the DC cable fuses are installed in the fuse holders.

#### CAUTION

Making an initial connection between the positive cable and the inverter's positive terminal may cause a spark. This is a normal and is a result of capacitors in the inverter starting to charge. Because of a possibility of sparking, it is important that both the inverter and the battery bank be positioned away from any source of flammable fumes or gases. Failure to heed this warning can result in fire or explosion. Do not make the first positive terminal connection immediately after flooded batteries have been charging. Allow time for the battery gasses to vent to outside air. If you are using sealed batteries, making this connection poses no danger.

8. Attach the positive cable end to the Positive (+) DC connector on the inverter. Make sure the connection is tight and secure.

9. Slide the connector/cable boot insulation over the bare terminal.

10. Turn ON (1) the inverter. The display on the front panel should show 10.5 to 15 volts depending on the voltage of the power source. When the voltage reading does not fall within this range, check the connections of the wires to the terminals on the power source and the inverter to make sure they are secure. Also check the

# 8000W Power Inverter

By Wagan Tech

voltage of the power source. Make certain that the High Temperature or Over Load LED Indicators are not lit.

11. Turn OFF (0) the inverter. The Over Load and High Temperature LEDs may briefly "flash". This is normal. The audible alarm may also sound a short "chirp". This is also normal.

12. When you have confirmed that the appliance to be operated is turned off, plug the appliance into one of the four AC Outlets on the front panel of the inverter.

13. Turn on the inverter.

14. Turn on the appliance.

#### Note:

If an extension cord is used from the inverter to the appliance, limit the extension cord length to 50 feet or less. Make sure that the cord is properly rated to carry the appliance load.

## 7. CHARGING THE BATTERY BANK

### 7.1 General Information

It is not the purpose of this Inverter User's guide to provide detailed information regarding battery charging systems. However, the user should try to augment any charging system with either wind power or solar power. These can continue to operate during power outages and they also recharge time.

### 7.2 Regular Loss Of Commercial Power

If the inverter system is used during commercial power outages that occur daily, configure the charger system to replace energy during the time that commercial power is available. Replacement of battery energy always requires more than was taken from the battery typically 130 percent. In the example used earlier in this document, the AC load ran for 10 hours. If commercial power is available, there are approximately 14 hours left in the day to do the recharging. The following is



an example of what is necessary to recharge a battery bank that has 16500 AH of capacity (as in the example above) and has been discharged to 10.5 volts (discharged). The charger has to replace 2145 AH (1650x 1.3 AH) in 14 hours. So the charger must charge at a rate of 153 Amps for 14 hours. As this charge current is distributed among the batteries in the battery bank, the current received by an individual battery is within its charge rating. Be sure that the battery is well vented as the area will likely have accumulations of an explosive mixture of hydrogen and oxygen. Follow all recommendations for use that are contained in the battery charger manual. If commercial automatic battery chargers do not have the capacity to fully recharge the battery bank within the required time, investigate using more than one automatic charger. Seek an expert to avoid charging too quickly and risking overheating the batteries.

**WARNING**

**THERE IS DANGER OF EXPLOSION. DO NOT CONNECT OR DISCONNECT CHARGER CABLES DIRECTLY AFTER BATTERY DISCHARGE OR RECHARGE –MAKE SURE THAT THE BATTERY BANK AREA IS WELL VENTED BEFORE ATTACHING OR REMOVING CABLES.**

If the flooded lead-acid batteries are used, as examples given in this document, be sure to make periodic checks of battery electrolyte levels. Follow battery manufacturer's instructions in keeping the electrolyte at the proper level. Be sure to use pure distilled water when replacing evaporated electrolyte liquid.

**7.3 Aboard A Vessel Or Vehicle**

Manufacturer-supplied, engine-driven alternators can usually be replaced with one that can continuously deliver higher amperage. This should be done at the outset. Keep the batteries charging when the vessel or vehicle engine is operating. In the case of a vessel, make sure that shore power is used to recharge the batteries whenever possible.

**8. OPERATING ISSUES TV AND AUDIO**

Although all inverters are shielded and filtered to minimize signal interference, some interference with your television picture may be unavoidable, especially with weak signals. However, here are some suggestions that may improve

**8000W Power Inverter**

By Wagan Tech

reception.

- First, make sure that the television antenna produces a clear signal under normal operating conditions (i.e., at home plugged into a standard 110/120V AC wall outlet). Also, ensure that the antenna cable is properly shielded and of good quality.
- Change the positions of the antenna cables and television power cord.
- Isolate the television, its power cord and antenna cables from the inverter by running an extension cord from the inverter to the television set.
- Coil the television power cord or install a clamp-on ferrite choke (available from electronic parts suppliers).

Note: Some inexpensive audio systems may have a slight "buzzing" sound when operated with the inverter. This is caused by insufficient filtering in the audio system. The only solution to this problem is to get a sound system with a higher quality power supply.

**9. TROUBLESHOOTING**

**PROBLEM: No Output Voltage**

Reason	Solution
Poor contact with battery terminals.	Shut down inverter and disconnect. Clean terminals thoroughly and reconnect
Blown DC battery fuse(s).	Turn off inverter. Replace fuse(s) with same type and rating

**PROBLEM: Inverter is Shut Down**

Reason	Solution
Battery voltage below 10 Volts	Recharge or replace battery.
Inverter is too hot (thermal shut down mode).	Allow inverter to cool. Check for adequate ventilation. Reduce the load on the inverter

	to rated continuous power output.
Unit may be defective.	See warranty and call customer service.

**PROBLEM: Low Battery Alarm on all the Time**

Reason	Solution
Input voltage below 10.5 Volts	Keep input voltage above 10.5 Volts to maintain regulation.
Poor or weak battery condition.	Recharge or replace battery.
Inadequate power being delivered to the inverter or excessive voltage drop.	Use lower gage (heavier) cable. Keep cable length as short as possible.

**PROBLEM: TV does not Work**

Reason	Solution
TV does not turn on.	Contact TV manufacturer to find out if the TV is compatible with a modified sine wave.

# 8000W Power Inverter

By Wagan Tech

## 10. SPECIFICATIONS

Name	Description
Input	12V (10-15V) DC
Output	115V AC
Output waveform	Modified Sine Wave (MSW)
Continuous power	8000 Watt
Surge power	16000 Watt
Efficiency	Approx. 90 %
Power Switch	ON/OFF Control
No load current	
Switch ON	<2.5 ADC
Switch OFF	<0.3 ADC
Battery low alarm	10.5 ± 0.5 V DC
Battery low shutdown	10 ± 0.5 V DC
AC output socket	4 North American Standard 15 amps
AC output terminals	Direct wiring up to 68 amps @ 115VAC (use 6 gage wire)
Dimensions	22.5 x 11 x 8.5 in. (570 x 280 x 215 mm) (L x W x H)
Net Weight	42.6 lb (19.2 kg)

**NOTE**

All specifications are typical at nominal line, half load, and 77deg F/ 25 deg C unless otherwise noted. Specifications are subject to change without notice.

## 11. DISPOSAL / RECYCLING OF INVERTER

Electronic products are known to contain materials that are toxic if improperly disposed. Contact local authorities for disposal and recycling information.

**12. WARRANTY – REGISTRATION FORM**

WAGAN Corp. Limited Warranty Registration Form
<p>All WAGAN Corporation products are warranted to the original purchaser of this product.</p> <p><b>Warranty Duration:</b> This product is warranted to the original purchaser for a period of one (1) Year from the original purchase date, to be free of defects in material and workmanship. WAGAN Corporation disclaims any liability for consequential damages. In no event will WAGAN Corporation be responsible for any amount of damages beyond the amount paid for the product at retail. In the event of a defective item, please ship the item, prepaid, with a complete explanation of the problem, your name, address and daytime phone number. WAGAN Corporation will, at its option, replace or repair the defective part. This warranty is void if the product has been damaged by accident, in shipment, unreasonable use, misuse, neglect, improper service, commercial use, repairs by unauthorized personnel or other causes not arising out of defects in materials or workmanship. This warranty is effective only if the product is purchased and operated in the USA and does not extend to any units which have been used in violation of written instructions furnished.</p> <p><b>Warranty Disclaimers:</b> This warranty is in-lieu of all warranties expressed or implied and no representative or person is authorized to assume any other liability in connection with the sale of our products. There shall be no claims for defects or failure of performance or product failure under any theory of tort, contract or commercial law including, but not limited to negligence, gross negligence, strict liability, breach of warranty and breach of contract.</p> <p><b>Warranty Performance:</b> During the above one (1) Year warranty period, a product with a defect will be replaced with a comparable model when the product is returned to WAGAN Corporation with an original store receipt. The replacement product will be in warranty for the balance of the one (1) Year warranty period.</p>

WAGAN Corp. Limited Warranty Registration Form				
<ul style="list-style-type: none"> <li>Please activate my limited warranty for WAGAN Corp.</li> <li>Enclosed copy of original sales receipt.</li> </ul>				
Name				
Mail Address				
Add'l Address				
City	State		Zip Code	
Item Purchased				
Store Name				
Date of Purchase				
Signature		Date		
<p>All WAGAN Corporation Products must be registered within (30) days of purchased to activate this warranty.</p> <p>Mail the complete registration form, along with a copy of the original receipt to:</p> <p style="text-align: center;">Attn: Customer Service                      WAGAN Corporation                      3589 Yale Way, Fremont, CA 94538                      Email: customerservice@wagan.com                      Phone: (Toll Free) 1-800-231-5806 (Local) 1-510-490-9221                      Hours of Operation: Monday through Friday 8:00 A.M. - 5:00 P.M. (P.S.T.)</p>				