

C12 Charge/Load/Lighting Controller Owner's Manual

xantrex[™]

t 1-800-670-0707 (toll free in North America)
1-360-925-5097 (direct)
f 1-800-994-7828 (toll free in North America)
1-360-925-5143 (direct)
e customerservice@xantrex.com
www.xantrex.com

March 2005
975-0130-01-01 Rev. D

Printed in China

Introducing the C12

The Xantrex Technology C12 charge/load controller is the finest small system charge/load controller available and has many capabilities previously either non-existent, or found only in separate products.

Numerous standard features maximize the performance of the system:

- Designed to meet the National Electric Code and other international controller specifications..
- Electronic overload and short circuit protection with automatic and manual reset ability. Increases the reliability of unattended systems by eliminating blown fuses or tripped circuit breakers.
- Field adjustment of the setpoints is provided by rotary controls with removable knobs to reduce the potential for setpoint tampering. Includes calibrated scales for adjustment of the settings and testpoints to verify setpoints using a digital meter (not required).
- Optional external plug-in temperature compensation sensor for automatic adjustment of the charge controller setpoints to the battery temperature. This UL requirement is also strongly recommended for sealed batteries.
- Over-temperature protection of the electronic circuitry is provided by reducing the charge rate. This improves the reliability of the C12 when used in very hot environments (over 113°F / 45°C ambient).
- Multi-color LED with matching color label for mode/status indication.
- Suitable for outdoor use when protected from direct rain and sunlight.
- 2 year limited warranty

These instructions only apply to the C12 REV D or later.

Operating Modes

The model C12 charge/load controller can operate in one or more of the following modes:

- **Photovoltaic Charge Control Mode** with 3-stage regulation and automatic or manual battery equalization cycle.
- **DC Load Control Mode** includes automatic low battery disconnect with warning by flashing the loads. In manual mode the reset switch allows one 10-minute "grace period" of load operation.
- **NITE-LITE Mode** with automatic dusk detection and adjustable time period from 10 minutes to 9.5 hours duration or dusk to dawn operation with a 20 hour limit.

Photovoltaic Charge Control Mode

3-Stage Regulation

The C12 charge controller rapidly cycles the photovoltaic array on and off to control the charging of the battery. The battery voltage will vary during the charging process, as follows:

1. **BULK**—During this stage the PV array is allowed to charge at its full output. Once the voltage of the battery reaches the BULK voltage setting, the controller goes to the next stage.
2. **ABSORPTION**—During this stage the voltage of the battery is held at the BULK voltage setting until a timer accumulates 1 hour.
3. **FLOAT**—During this stage the voltage of the battery is held at the FLOAT voltage setting. Full current from the PV array can still be delivered to the loads during this stage.

If the voltage of the battery drops below the FLOAT setting for a cumulative period of one hour, a new BULK or ABSORPTION cycle will be triggered. This typically occurs during each night. If the battery is full at the start of the day, it will receive only an ABSORPTION charge for 1 hour and then be held at the FLOAT setting for the remaining period of the day unless the battery is discharged.

This 3-stage charging process results in faster recharging of batteries compared to on-off or constant voltage regulators. Faster recharging increases the performance of the system by storing more of the PV

array's limited output. The final FLOAT voltage setting reduces gassing of the battery, minimizing watering requirements and ensuring the complete recharge of the battery.

Automatic PV Array Night Disconnection

Each night the PV array is automatically disconnected from the battery to prevent reverse leakage of power. This eliminates the need for a blocking diode between the battery and the PV array. If you are using thin-film or amorphous solar modules, diodes may still be required to prevent damage from partial shading conditions. Check the documentation provided for the requirements of your PV modules.

Equalization (Non-Sealed Batteries Only)

Approximately every month, the batteries may need to be "equalized" (a fancy term for over-charged). Since the individual cells of the battery are not identical, some cells may not be fully charged when the charging process is completed. Or, if the batteries have been left uncharged for periods of time, the plates will have sulfates on them. If the sulfate remains on the plates for an extended period of time, it will harden and seal off a percentage of the plate area, reducing the capacity of the battery. By equalizing the batteries, the sulfate is removed from the plates.

Additionally, batteries with liquid electrolyte may become stratified. Stratification concentrates the sulfuric acid into the bottom of the cell while the top becomes diluted. This corrodes the lower portion of the plates, reducing battery life. Mixing of the electrolyte by the formation of gas bubbles during the equalization process reduces stratification.

You can check if a battery needs to be equalized by two methods. If you can measure the voltage of each individual cell, a variation of 0.05 volts between cells indicates an imbalance exists. If the battery construction prevents measurement of the individual cell voltages, use a hydrometer. If you can measure the specific gravity of each of the battery cells, a variation of 0.020 is considered significant. Both conditions may be corrected by an equalization charge.

A proper equalization charge will not damage a vented, liquid electrolyte type battery. It may, however, cause significant electrolyte usage and require that the battery be refilled with distilled water to the correct level. This may be a problem with unattended systems in remote areas that do not receive regular maintenance. Consult the battery manufacturer for their recommendations.

CAUTION: Equalization should only be done with vented (not sealed or maintenance free) lead acid, liquid electrolyte batteries. The battery manufacturer should be consulted before attempting to equalize any other type battery. Clean, distilled water will need to be added to the battery AFTER the equalization process.

DC loads may need to be disconnected by turning off circuit breakers or removing fuses before equalization to prevent damage by the required higher voltages. Just turning off the DC loads by its on/off switch may not provide protection.

WARNING: If the batteries are equipped with HYDROCAPS (catalytic gas recombiner caps), they should be removed during the equalization process. If hydrocaps are used, you should disable automatic equalization to prevent possible damage.

The C12 includes both automatic and manual triggering of the equalization process. Automatic equalization is enabled by removing the jumper located on bottom right corner the circuit board next to the reset switch (the default setting is disabled). An equalization charge, (holding the voltage 1 volt above bulk for 2 hours) will occur every 30 days or once the system has reached the LVD level for a period of two minutes or longer. The default setting is auto equalization disabled.

Manual equalization is not available when the C12 is used in the NITE-LITE mode because the reset switch provides a test function of the loads instead (this only applies to the NITE-LITE mode).

Manual Equalization

Manual equalization of the battery can be enabled by pressing and holding the reset switch until the LED indicator begins to alternate between red and green. The equalization process will continue until the batteries have been held above the bulk setting for two hours of accumulated time. The battery voltage will be limited to 1 volt above the BULK setting during this period. Once two hours have been accumulated, the C12 will return to the FLOAT stage of the charging process (with NiCad batteries the battery voltage is held at the BULK setting for a two hour period before it returns to the float level).

To stop the equalization process, press and hold the reset switch until the LED stops alternating between red and green. If the equalization process was shorter than 1 hour, the C12 will continue with a BULK charge cycle and then hold the battery at the BULK setting for one hour (the absorption stage) before returning to the FLOAT setting.

During the equalization process the LED will alternate between red and green and will not provide any other mode/status indication.

Manual equalization is not available when operating the controller in the NITE-LITE mode. Pressing the reset switch in this mode provides a test of the loads (the lights) for a period of two minutes.

Automatic Equalization

The C12 can automatically trigger an equalization charge every 30 days or after the voltage drops below the LVD setting for a period of two minutes. The LED will indicate that the equalization process is occurring only once the battery voltage has risen above the bulk setting.

To enable automatic equalization, the jumper located at the bottom right corner of the circuit board must be removed. The default setting of the C12 is automatic equalization disabled.

To stop the equalization process, press and hold the reset switch on the bottom of the C12 until the LED indicator stops alternating between red and green. If the equalization process was shorter than 1 hour, the C12 will continue with a BULK charge cycle and then hold the battery at the BULK setting for one hour (the absorption stage) before returning to the FLOAT setting.

Electronic Overcurrent Protection

During operation, the C12 continuously monitors the current flowing into and out of the battery. If the current exceeds 15 amps the transistor switches are opened, stopping the flow of electricity. This protects the loads and array wiring from short circuits and overloads. The detection circuitry is faster than breakers or fuses—they will not trip or blow when a fault occurs because the C12 will protect sooner.

The C12 will automatically attempt to restart the load 12 seconds after the overcurrent condition was detected. If the overcurrent reoccurs when the system is re-energized, it turns off again. A second attempt to restart the system will occur after an additional 12 seconds. If this fails, the C12 will try to restart the system every 15 minutes.

The reset switch on the bottom of the C12 allows the user to attempt a manual restart at any time. When the controller is unable to automatically restart the system, check the wiring and reduce the loads connected. Allow for up to a 12-second delay after pressing the reset switch for the restart to occur.

The current shunt which is used to measure the current flow is located in the positive conductor of the circuit. This allows you to use any combination of the negative terminals, as they are all common to one another.

Temperature Compensation

The optional plug-in external temperature sensor automatically fine-tunes the charging process of the C12. If the temperature sensor is installed, the regulation setpoints should be adjusted for a battery at 23°C/74°F. The C12 adjusts the BULK and FLOAT setpoints -0.03v per °C for lead acid type batteries and -0.02v per °C for NiCad type batteries.

If the temperature sensor is not installed, the setpoints should be adjusted to account for the temperature of the battery during operation. Seasonal adjustment of the setpoints may be necessary to prevent battery damage and to ensure proper charging.

Over-temperature Protection

The temperature of the C12's transistors is also continuously monitored. This protects the charge controller from damage in high-temperature environments. If excessive temperatures are detected, the charge control transistor is rapidly turned off and on to reduce the charge rate. This will reduce the transistor temperature.

If the PV array current is reduced to zero and the over-temperature condition continues, the load will be disconnected. Once the temperature has dropped, the PV array and then the loads will be reconnected.

The C12 is rated for 12 amps continuous at up to 45°C/113°F and 8 amps at up to 65°C/150°F.

Battery Loss Detection

If the battery is disconnected from the system while the PV array is charging, the C12 will prevent damage to DC loads by a high voltage condition (over 18 volts) by disconnecting the PV array. The C12 also prevents oscillation of the system (on-off-on...) which is common with other controllers when the battery has been disconnected but the PV array remains connected.

DC Load Control Mode

The C12 includes a 12-amp load control to manage the discharging of the battery. This prevents damage to the battery from over-discharge during periods of poor weather or excessive loads.

The C12 load controller is unique in that it includes a warning flash of the loads (off then on) to alert the user that the load will be turned off after an additional 5 minute delay period. This gives the user an opportunity to reduce the loads and extend operation of the system.

Once the load has been disconnected, the user is given a one time; 10-minute "grace" period of load operation immediately after the reset switch has been pressed. This allows the user to operate critical loads for a limited period. The small additional discharge of the battery will not cause any harm.

Reconnection of the load is allowed once the battery voltage has exceeded the Low Voltage Reconnect (LVR) setting. The default setting of the C12 is manual reconnection (MANUAL) of the loads after the system has reached the LVD state. Manual reconnect is selected by turning the bottom knob fully counter-clockwise to MANUAL.

Automatic Reconnection

Automatic reconnection of the loads at the LVR setting can be enabled by adjusting the bottom-most knob to the area marked as AUTO RECON instead of the default MANUAL area.

In automatic reconnection mode, no warning flash of the loads is provided. Pressing the reset switch does not provide the one time, 10 minute additional "grace period" of load operation included in the manual reconnection mode.

The low voltage disconnect includes a 2 minute delay before disconnecting the loads when the voltage drops below the LVD setting when automatic reconnection is selected.

NITE-LITE Mode

The C12 can also be used to automatically control photovoltaic lighting systems. Up to 12 amps of lights can be controlled by the C12.

The installation and reliability of the system is maximized by using the PV array as the photocell to provide dusk and dawn detection. When the PV array voltage drops below 3.5 volts for a period exceeding 60 seconds, the C12 turns on the lights. If the PV array voltage exceeds 3.5 volts for 60 seconds, the C12 turns off the lights. When the PV array voltage exceeds 9 volts the C12 resets the NITE-LITE-TIME period counter for the next day's operation.

To activate the NITE-LITE mode, select a run duration setting by adjusting the knob at the bottom of the circuit board labeled as NITE-LITE-TIME. The minimum run time is 10 minutes and the maximum is 9.5 hours (automatic reset is standard for the NITE-LITE mode).

If the voltage falls below the LVD setting for more than 2 minutes, the lights will be turned off to prevent damage to the battery. The LVD will auto-reset once the charging process increases the voltage above the

LVR setting, usually during the next day. No warning flash occurs before the lights are turned off when NITE-LITE mode is selected.

Dusk-Dawn Operation

If the NITE-LITE-TIME knob is turned fully clockwise to the area marked D-D, dawn to dusk operation will be selected. This allows the lights to operate all night, turning on at dusk and off at dawn.

If the voltage falls below the LVD setting for more than 2 minutes, the lights will be turned off to prevent damage to the battery. The LVD will be reset once the charging process increases the voltage above the LVR setting, usually during the next day. No warning flash will occur before the lights are turned off when D-D mode is selected. In D-D mode the run time is limited to a maximum of 20 hours.

Testing the Lights with the Reset Switch

Pressing the reset switch in NITE-LITE mode allows testing of the lights. They will be turned on even if it is daytime or if the controller has disconnected the lights due to a low voltage condition. This is intended to allow easier troubleshooting of systems in the field.

Equalization Mode with NITE LITE Mode

Manual equalization is not available when operating the controller in NITE-LITE mode. The reset switch is used to provide the test mode for checking the operation of the lights. Automatic equalization is allowed but can be disabled by removing the circuit board jumper.

LED Mode Indicator

A multi-color LED indicator is provided to indicate the operating status of the C12. A color-coded label is included on the cover of the C12 to explain LED operation.

Important: The green and red color of the LED only indicates the particular operating mode and the battery voltage level. It does not indicate whether the charging source is functioning properly.

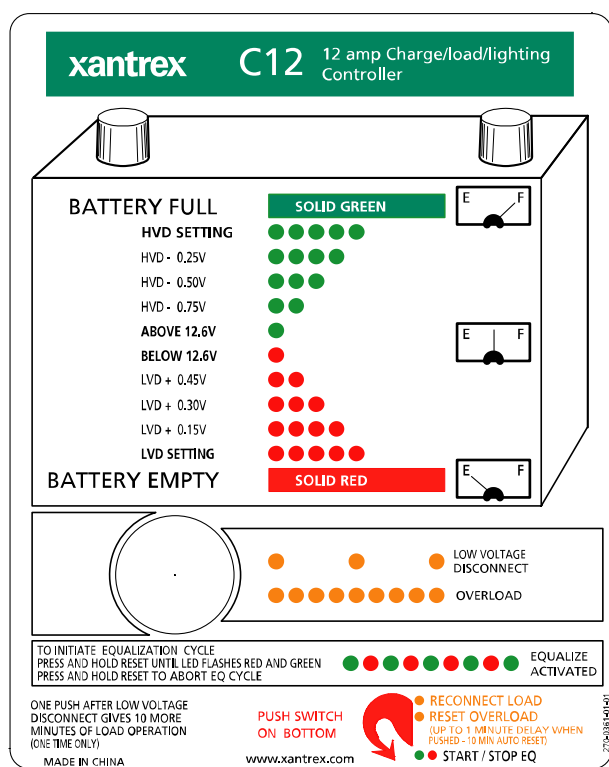

The LED indicator can display the following conditions:

- **Solid Green**—The battery has entered the FLOAT stage of the charging process. The LED will remain solid into the night unless the batteries drop below 12.6 volts. This allows the user to confirm that the system reached FLOAT during the charging process when checked at the end of the day. Reaching the FLOAT stage frequently

is a good indication of proper system operation and will maximize battery life and performance.

- **Blinking Green**—The battery voltage is above 12.6 volts. As the battery voltage approaches the BULK setting, the LED will blink green several times (up to 5) and then pause. This indicates that the battery voltage is approaching the BULK voltage setting and provides an indication that the battery is almost full.
- **Blinking Red**—The battery voltage is below 12.6 volts. As the battery voltage approaches the Low Voltage Disconnect (LVD) setting, the LED will blink red several times (up to 5) and then pause. This provides an indication that the battery is almost empty.
- **Solid Red**—The battery has reached the Low Voltage Disconnect (LVD) setting. If manual reconnect mode was selected, the loads will be turned off momentarily (flashed) to warn the user that the battery is empty after a 2-minute delay. The loads will then be disconnected after an additional 5-minute delay unless the user reduces the loads to a point that the battery voltage exceeds the LVD setting. If auto reconnect mode was selected, the loads will be turned off after a 2-minute delay without any warning flash.
- **Slow Blinking Orange**—The C12 has disconnected the loads due to reaching the LVD setting. The user can press the reset switch for a one time 10-minute "grace" period or can wait until the voltage rises above the LVR setting to allow a manual or automatic reset to occur. If manual reconnect was selected, the loads will not resume operation until the reset switch has been pressed.
- **Fast Blinking Orange**—The C12 has detected a short circuit and has disconnected the loads. The C12 will try to automatically restart the loads after a 12-second delay. If the loads will not restart, turn off all loads and press the reset switch. If the C12 then restarts, the loads may be too large. Up to a 12 second delay may occur before the C12 attempts to restart after pressing the reset switch.
- **Alternating Red and Green**—The C12 is in equalize mode. It will automatically stop the equalization process after accumulating two hours of operation at a voltage above the BULK setting. The user can stop the equalization process at any time by pressing the reset switch until the LED stops alternating red and green.

Batteries

Batteries come in different sizes, types, amp hours, voltages and chemistries. There are nearly as many descriptions of exactly how batteries should be charged, as there are people willing to offer explanations. It is not possible here to discuss all aspects in detail. However, here are some basic guidelines that will help in battery selection and ensure that the batteries used are far better maintained than the majority. The best source of the most appropriate settings for the C12 will be from the manufacturer or supplier of the batteries.

Automotive Batteries

Automotive and truck batteries are designed for high cranking power, but not deep cycling. Don't use them unless no other battery type is available. They simply will not last long in a cycling application.

Maintenance-Free Batteries

This type of battery is often sold as a RV or marine battery, but is rarely appropriate for use with a PV system. This battery typically has an additional reserve of liquid electrolyte in each cell to minimize the need to add electrolyte. This is not the same as a sealed battery.

Deep Cycle Batteries

This is the type of battery best suited for use with PV systems. They are designed to have the majority of their capacity used before being recharged. They are available in many sizes and types. The most common type is the non-sealed liquid electrolyte battery.

Non-sealed types have battery caps. The caps should be removed periodically to check the level of electrolyte. When a cell is low, distilled water should be added **after the battery is fully charged**. If the level is extremely low, add only enough distilled water to cover the plates before recharging. The electrolyte volume increases during the charging process and the battery will overflow if it is filled all of the way

up before recharging. Only distilled water should be used, as any impurities will reduce battery performance and life.

A popular and inexpensive deep cycle battery is the "golf cart" battery. It is a 6-volt design typically rated at 220 amp hours. RV and Marine deep cycle batteries are also popular for small systems. They are usually referred to as Group 24 or group 27 and are rated at 80 to 100 amp hours at 12 volts. Many larger systems use L16 batteries. These are usually rated at 350 amp hours at 6 volts each. They are 17 inches in height and weigh around 130 pounds—which may be a problem in some applications. 8D batteries are available with either cranking or deep cycle construction. Purchase only the deep cycle version. The 8D is typically rated at 220 amp hours at 12 volts.

Sealed Batteries

Another type of battery construction is the sealed gel cell. They don't use battery caps. The electrolyte is in the form of a gel rather than a liquid, which allows the batteries to be mounted in any position. The advantages are no maintenance, long life (800 cycles claimed) and low self-discharge. Absorbed electrolyte is also acceptable. Their electrolyte is contained in mats between the battery plates.

Nickel-Cadmium and Nickel-Iron Batteries

The Xantrex C12 is compatible with Nickel-Cadmium (NiCad) and Nickel-Iron (NiFe) type batteries, which must be charged to a higher voltage level to achieve a full charge. To enable use of the C12 with NiCad batteries, cut the resistor labeled as R36 on the lower left corner of the C12 circuit board. This adds two volts to the printed scale on the circuit board around the BULK and FLOAT potentiometers.

Adjust the Bulk Charge Voltage to the setting recommended by the battery manufacturer. Remember to add 2 volts to the scale shown when making the adjustment.

Float Voltage settings for NiCad/NiFe batteries should also be set to the battery manufacturer's recommendations. Remember to add 2 volts to the scale when making the adjustment.

Note: In some applications the BULK voltage setting should be adjusted to a level below the maximum operating voltage of the DC loads. This may be as low as 15 volts for some types of electronic loads. Check with the manufacturers of the equipment being used.

Battery Sizing

Batteries are the fuel tank of the system. The larger the batteries, the longer the system can operate before recharging is necessary. An undersized battery bank results in short battery life and disappointing system performance.

To determine the proper battery bank size, compute the number of amp hours that will be used between charging cycles. Once the required amp hours are known, size the batteries at approximately twice this amount. Doubling the expected amp hour usage ensures that the batteries will not be overly discharged and extends battery life. Battery requirements can also be calculated using the nameplate rating of appliances. The critical formula is Watts = Volts × Amps. Divide the wattage of the load by the battery voltage to determine the amperage the load will draw from the batteries. Multiply the amperage times the hours of operation and the result is, reasonably enough, amp-hours.

IMPORTANT SAFETY INSTRUCTIONS

SAVE THESE INSTRUCTIONS!

This manual contains important safety and operating instructions as prescribed by ANSI/UL specifications for charge controllers used in photovoltaic applications. This manual covers Xantrex Technology model number C12 charge / load controller for use in Residential and Commercial photovoltaic applications.

General Precautions

1. Before using the charge/load controller, read all instructions and cautionary markings on (1) the charge/load controller (2) the batteries and (3) the photovoltaic panels.

2. **CAUTION**—To reduce risk of injury, charge only deep cycle lead acid, lead antimony, lead calcium, gel cell, absorbed mat, NiCad or NiFe type rechargeable batteries. Other types of batteries may burst, causing personal injury and damage.
3. Do not attempt to repair the C12. Take it to a qualified service center when service or repair is required. Incorrect re-assembly may result in a risk of electric shock or fire.
4. To reduce risk of electric shock, disconnect all wiring before attempting any maintenance or cleaning. Turning off controls will not reduce this risk. Solar modules produce power when exposed to light—cover them with opaque material before servicing.
5. **WARNING**—WORKING NEAR A LEAD ACID BATTERY IS DANGEROUS. BATTERIES GENERATE EXPLOSIVE GASES DURING NORMAL OPERATION. Provide ventilation to outdoors from the highest point of the battery compartment.
6. NEVER charge a frozen battery.
7. No terminals or lugs are required for hook-up of the DC wiring. Wiring should be rated for 75 °C and should be no less than 14 AWG / 2.1 mm² gauge wire. Terminals provided accept up to 10 AWG / 5.2 mm² gauge stranded wire.
8. Insulate tool handles with tape etc. to reduce the chance of a short circuit occurring. Spark or short-circuits can cause an explosion.
9. Tools required to make DC wiring connections: Wire strippers, Phillips screwdriver #2, Slotted screwdriver 5/32" (4.5 mm).
10. This charge/load controller is intended to be used with a battery supply of 12 VDC nominal voltage.
11. Instructions for mounting: See mounting instruction section.
12. For battery installation and maintenance: read the instructions provided with the batteries prior to operating.
13. No DC disconnect switch is provided as an integral part of this unit. DC disconnects may be required as part of the system installation. Refer to local electrical codes for requirements.
14. No overcurrent protection for the battery supply is provided as an integral part of this unit. Over current protection of the battery cables must be provided as part of the system installation. Refer to local electrical codes for requirements.
15. Although over current protection for the DC output wiring is provided as an integral part of this unit, additional over current protection of the DC output wiring may be required as part of the system installation. Refer to local electrical codes for requirements.
16. **GROUNDING INSTRUCTIONS**—This charge/load controller should be connected to a grounded, metal, permanent wiring system. Connections to the grounding system should comply with all local codes and ordinances.

Personal Precautions

1. Someone should be within range of your voice or close enough to come to your aid when you work near batteries.
2. Have plenty of fresh water and soap nearby in case battery acid contacts skin, clothing, or eyes.
3. Wear eye protection and protective clothing. Avoid touching eyes while working near batteries.
4. If battery acid contacts skin or clothing, wash immediately with soap and water. If acid enters an eye, immediately flood the eye with running cold water for at least 15 minutes and get medical attention immediately.
5. Baking soda neutralizes spilled Lead Acid electrolyte. Vinegar neutralizes spilled NiCad electrolyte. Keep a supply on hand.
6. **NEVER** smoke or allow a spark or flame in vicinity of a battery or generator.
7. Be extra cautious to reduce the possibility of dropping a metal tool onto batteries. It might spark or short-circuit batteries or other electrical parts that may cause an explosion. Cover wrench handles with plastic tape or vinyl dip coating material.
8. Remove personal metal items such as rings, bracelets, necklaces, and watches while installing the system. A single battery can

produce short-circuit current high enough to weld a ring to a battery terminal or like metal, causing severe burns.

Installation

Mounting

The enclosure should be mounted vertically on a wall or pole with the provided mounting screws (#10 x 3/4" sheet metal screws). The knockout must be located at the bottom. Either the provided strain-relief clamp or conduit should be used to prevent damage to the circuit board and terminal block from pulling on the wires. The cover should be replaced and retained with the provided screw (#10 x 3/8" sheet metal screw).

Although the C12 is designed for outdoor mounting, it should not be mounted outdoors with direct exposure to rain or sun. If necessary, provide a cover that adequately protects the unit from direct sunlight and direct rain, and that reduces heating of the enclosure and subsequent higher operating temperatures.

In severe environments additional consideration should be taken to minimize exposure to wet environments. The use of conformal-coated circuit boards, plated terminals, powder coated metal components, and stainless steel fasteners improves tolerance to hostile environments.

Caution: It is in your best interests to install the C12 in a dry, protected location away from sources of high temperature and moisture. Exposure to saltwater is particularly destructive. Corrosion of the circuit board is not covered by the warranty.

Do **not** locate the C12 in a sealed compartment with the batteries. Batteries can generate hydrogen sulfide gas, which is very corrosive to electronics equipment and everything else. They also generate hydrogen and oxygen. If accumulated, this mixture could be ignited by an arc caused by the connection of a battery cables, or a loose terminal, etc.

Installation inside of a ventilated enclosure with sealed batteries is acceptable.

Wiring

The wiring, overcurrent protection devices and installation methods used should conform to all local electrical codes requirements.

The minimum recommended wire gauge is 14 AWG / 2.1mm² with a 75°C insulation rating. The terminals on the C12 will accept up to 10 AWG / 5.2 mm² wire. No crimp-on terminals or lugs are required.

Wiring should be protected from physical damage with 1/2" conduit or the strain relief clamp provided. You should pull the temperature sensor cable through the conduit first as the connector may not fit if other wires have been pulled first.

Three 1/2" conduit openings are provided in the chassis. The back has a knockout that can be removed if the wire will enter a wall or pole from directly behind the controller.

As a minimum, a 20 amp DC rated fuse in an appropriate fuse holder or disconnect switch should be provided near the battery for protection from short circuits. Local electrical codes should be consulted for wire sizing and any additional installation requirements.

If between two values shown, round up to next larger wire size.

Grounding

The C12 is designed to work with both negative ground and ungrounded electrical systems. The metal chassis of this charge/load controller can be grounded by installing the included green screw into the metal chassis in the hole to the right of the terminal block. This must then be connected with a copper wire to a grounding electrode such as a ground rod driven into the earth. If a negative ground system is desired, connect the negative current carrying conductor to the grounding system at one point in the system. Consult local electrical codes for more information and any additional requirements.

Adjusting the C12

The operation of the C12 is fully adjustable via rotary potentiometer controls. The knobs are removable to reduce the likeliness of a user tampering with the settings. Calibrated scales are provided to allow setting of the control without requiring the use of a digital voltmeter. Visual adjustment allows an accuracy of +/- 0.1 volts.

Typical BULK and FLOAT Setpoints for Common Battery Types

Battery Type	BULK (VDC)	FLOAT (VDC)
Sealed Gel or AGM Lead Acid battery	14.1 VDC	13.5 VDC
Maintenance-free RV/Marine Lead Calcium battery	14.3 VDC	13.2 VDC
Deep-cycle, Liquid Electrolyte Lead Antimony battery	14.6 VDC	13.4 VDC
NiCad or NiFe Alkaline battery* (using 10 cells in series)	16.0 VDC	14.5 VDC

* For NiCad and NiFe battery you must clip R36 and add 2V to the values for BULK and FLOAT shown on the circuit board. For example, to set the BULK for 16.0V, adjust the BULK's knob to 14.0V after clipping R36. Values above are for batteries at room temperature.

Temperature Compensating the Setpoints

If a temperature compensation sensor is installed the charge controlling process will be automatically adjusted for the battery temperature. Set the BULK and FLOAT settings for a battery at normal room temperature (23°C/74°F).

If no temperature compensation sensor is installed and the batteries will be operating in very hot or very cold conditions, adjust the BULK and FLOAT settings to allow for the battery temperature. The recommended change is 0.030 volts per degree Celsius for lead acid batteries and 0.020 volts per degree Celsius for NiCads. The setting should be lowered for hot climates and raised for cool climates. If significant seasonal variations are common, you will have to change the settings several times a year to prevent battery damage and ensure proper operation.

Recommended Wire Size & Maximum One-Way Distance (2% loss)						
Size each wire individually: C12 to array, C12 to battery & C12 to load						
Load/Array Amps	2.5A	5.0A	7.5A	10.0A	12.5A	15.0A
#14 AWG 2.1mm ²	20 ft 6 m	10 ft 3 m	6.5 ft 2 m	5 ft 1.5 m	4 ft 1.2 m	3 ft 1 m
#12 AWG 3.3 mm ²	30 ft 9 m	15 ft 4.5 m	10 ft 3 m	7 ft 2 m	6 ft 1.8 m	5 ft 1.5 m
#10 AWG 5.2 mm ²	50 ft 15 m	25 ft 7.5 m	16 ft 5 m	12 ft 3.5 m	10 ft 3 m	8 ft 2.5 m

Testpoints for Voltage Settings

If greater accuracy is desired, or if the knobs have been removed, testpoints are provided for measurement of each setting. A digital voltmeter needs to be connected from the BAT- terminal on the circuit board and the small testpoint located to the left of each adjustment pot at the 9 o'clock position. The testpoint provides a reading from 0 to 2 volts—this value must be added to the lower value of the adjustment range (HVD=13.0, HVR=12.5, LVR=12.0, LVD=10.5).

For example, to set the BULK (HVD) voltage to 14.4 volts, adjust the pot until the testpoint reads 1.4 volts ($13.0\text{ V} + 1.4\text{ V} = 14.4\text{ V}$).

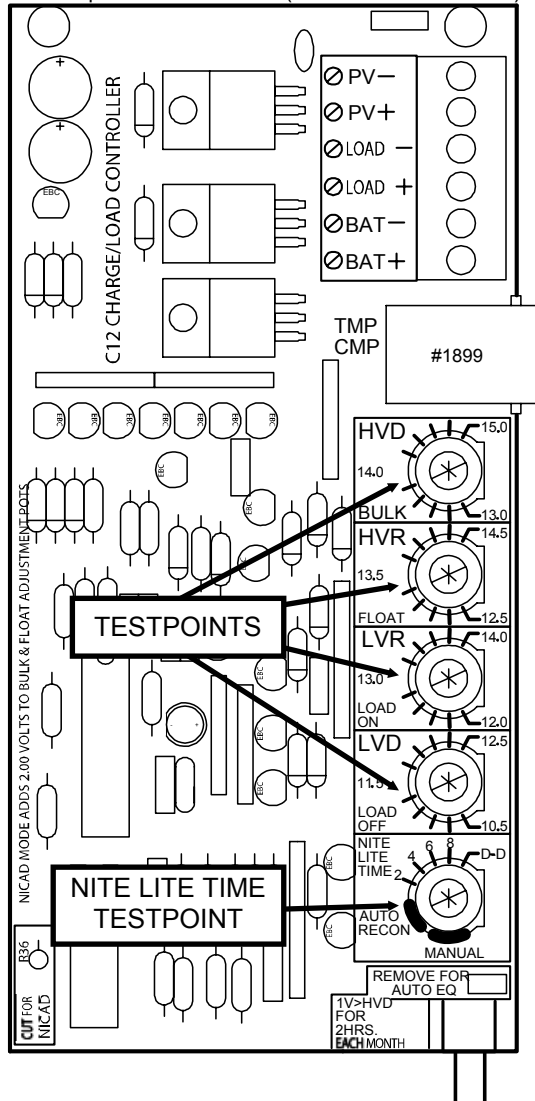

C12 circuit board shown

Testpoint for NITE LITE TIME

A testpoint is also provided to assist with the precise adjustment of the NITE LITE TIME control. Measurement of the testpoint with a digital voltmeter provides a voltage reading that can be used to validate the control knob's setting by comparing with the ranges shown below.

NITE LITE TIME Adjustment Using the Testpoint

Testpoint Reading	Mode or Time Period of Light Operation
0.50V to 1.40V	Manual reset of loads required after LVD
1.45V to 2.65V	Automatic reset of loads after LVD
2.70V to 4.90V +0.04V = 10 min.	NITE LITE mode with adjustable time period Adjustable in 10 min. periods up to 9.5 hours
4.92V to 5.00V	D-D mode (Dusk to Dawn / 20 hours max.)

Measurement needs to be from testpoint to BAT- terminal on the C12

Typical Installation

Basic installation of a small photovoltaic system with the C12 is shown below. The fuses are needed to protect against short circuits of the battery and the wiring to the C12. Disconnects may be required and are not shown. The PV array frame, C12 chassis and DC loads should be grounded. Check your local electrical code requirements.

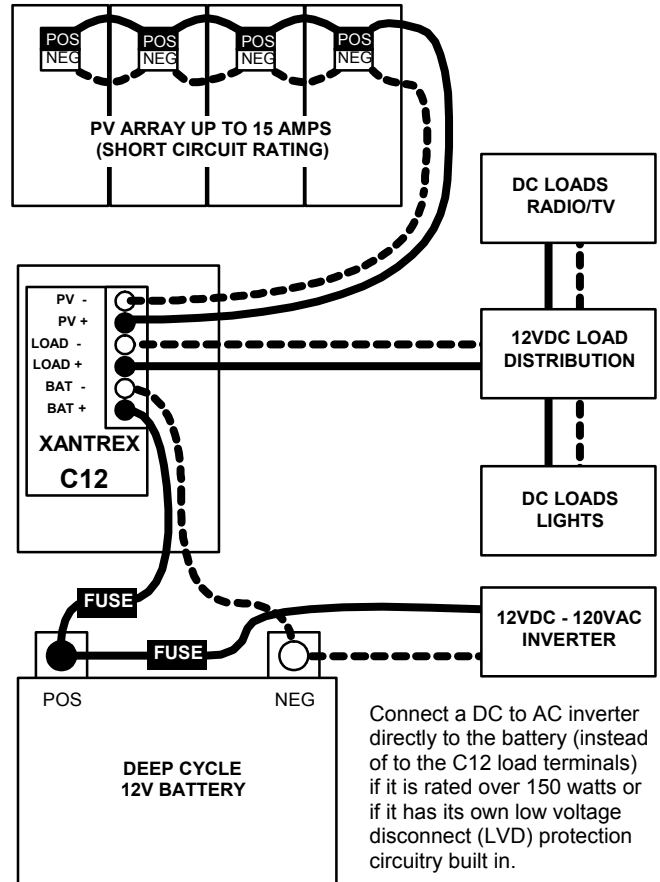

Connect a DC to AC inverter directly to the battery (instead of to the C12 load terminals) if it is rated over 150 watts or if it has its own low voltage disconnect (LVD) protection circuitry built in.

Limited Warranty

What does this warranty cover?

This Limited Warranty is provided by Xantrex Technology, Inc. ("Xantrex") and covers defects in workmanship and materials in your Xantrex C12. This warranty period lasts for two (2) years from the date of purchase at the point of sale to you, the original end user customer. You require proof of purchase to make warranty claims.

What will Xantrex do?

Xantrex will, at its option, repair or replace the defective product free of charge, provided that you notify Xantrex of the product defect within the Warranty Period, and provided that Xantrex through inspection establishes the existence of such a defect and that it is covered by this Limited Warranty.

Xantrex will, at its option, use new and/or reconditioned parts in performing warranty repair and building replacement products. Xantrex reserves the right to use parts or products of original or improved design in the repair or replacement. If Xantrex repairs or replaces a product, its warranty continues for the remaining portion of the original Warranty Period or 90 days from the date of the return shipment to the customer, whichever is greater. All replaced products and all parts removed from repaired products become the property of Xantrex.

Xantrex covers both parts and labor necessary to repair the product, and return shipment to the customer via a Xantrex-selected non-expedited surface freight within the contiguous United States and Canada. Alaska and Hawaii are excluded. Contact Xantrex Customer Service for details on freight policy for return shipments outside of the contiguous United States and Canada.

How do you get service?

If your product requires troubleshooting or warranty service, contact your merchant. If you are unable to contact your merchant, or the merchant is unable to provide service, contact Xantrex directly at:

Telephone: 1 800 670 0707 (toll free North America)

1 360 925 5097 (direct)

Fax: 1 800 994 7828 (toll free North America)

1 360 925 5143 (direct)

Email: customerservice@xantrex.com

Direct returns may be performed according to the Xantrex Return Material Authorization Policy described in your product manual. For some products, Xantrex maintains a network of regional Authorized Service Centers. Call Xantrex or check our website to see if your product can be repaired at one of these facilities.

What proof of purchase is required?

In any warranty claim, dated proof of purchase must accompany the product and the product must not have been disassembled or modified without prior written authorization by Xantrex.

Proof of purchase may be in any one of the following forms:

- The dated purchase receipt from the original purchase of the product at point of sale to the end user, or
- The dated dealer invoice or purchase receipt showing original equipment manufacturer (OEM) status, or
- The dated invoice or purchase receipt showing the product exchanged under warranty

What does this warranty not cover?

This Limited Warranty does not cover normal wear and tear of the product or costs related to the removal, installation, or troubleshooting of the customer's electrical systems. This warranty does not apply to and Xantrex will not be responsible for any defect in or damage to:

- a) the product if it has been misused, neglected, improperly installed, physically damaged or altered, either internally or externally, or damaged from improper use or use in an unsuitable environment;
- b) the product if it has been subjected to fire, water, generalized corrosion, biological infestations, or input voltage that creates operating conditions beyond the maximum or minimum limits listed in the Xantrex product specifications including high input voltage from generators and lightning strikes;
- c) the product if repairs have been done to it other than by Xantrex or its authorized service centers (hereafter "ASCs");
- d) the product if it is used as a component part of a product expressly warranted by another manufacturer;
- e) the product if its original identification (trade-mark, serial number) markings have been defaced, altered, or removed.

Disclaimer

Product

THIS LIMITED WARRANTY IS THE SOLE AND EXCLUSIVE WARRANTY PROVIDED BY XANTREX IN CONNECTION WITH YOUR XANTREX PRODUCT AND IS, WHERE PERMITTED BY LAW, IN LIEU OF ALL OTHER WARRANTIES, CONDITIONS, GUARANTEES, REPRESENTATIONS, OBLIGATIONS AND LIABILITIES, EXPRESS OR IMPLIED, STATUTORY OR OTHERWISE IN CONNECTION WITH THE PRODUCT, HOWEVER ARISING (WHETHER BY CONTRACT, TORT, NEGLIGENCE, PRINCIPLES OF MANUFACTURER'S LIABILITY, OPERATION OF LAW, CONDUCT, STATEMENT OR OTHERWISE), INCLUDING WITHOUT RESTRICTION ANY IMPLIED WARRANTY OR CONDITION OF QUALITY, MERCHANTABILITY OR FITNESS FOR A PARTICULAR PURPOSE, ANY IMPLIED WARRANTY OF MERCHANTABILITY OR FITNESS FOR A PARTICULAR PURPOSE TO THE EXTENT REQUIRED UNDER APPLICABLE LAW TO APPLY TO THE PRODUCT SHALL BE LIMITED IN DURATION TO THE PERIOD STIPULATED UNDER THIS LIMITED WARRANTY.

IN NO EVENT WILL XANTREX BE LIABLE FOR ANY SPECIAL, DIRECT, INDIRECT, INCIDENTAL OR CONSEQUENTIAL DAMAGES, LOSSES, COSTS OR EXPENSES HOWEVER ARISING WHETHER IN CONTRACT OR TORT INCLUDING WITHOUT RESTRICTION ANY ECONOMIC LOSSES OF ANY KIND, ANY LOSS OR DAMAGE TO PROPERTY, ANY PERSONAL INJURY, ANY DAMAGE OR INJURY ARISING FROM OR AS A RESULT OF MISUSE OR ABUSE, OR THE INCORRECT INSTALLATION, INTEGRATION OR OPERATION OF THE PRODUCT.

Exclusions

If this product is a consumer product, federal law does not allow an exclusion of implied warranties. To the extent you are entitled to implied warranties under federal law, to the extent permitted by applicable law they are limited to the duration of this Limited Warranty. Some states and provinces do not allow limitations or exclusions on implied warranties or on the duration of an implied warranty or on the limitation or exclusion of incidental or consequential damages, so the above limitation(s) or exclusion(s) may not apply to you. This Limited Warranty gives you specific legal rights. You may have other rights which may vary from state to state or province to province.

Warning: Limitations On Use

Please refer to your product manual for limitations on uses of the product.

SPECIFICALLY, PLEASE NOTE THAT THE XANTREX C12 SHOULD NOT BE USED IN CONNECTION WITH LIFE SUPPORT SYSTEMS OR OTHER MEDICAL EQUIPMENT OR DEVICES. WITHOUT LIMITING THE GENERALITY OF THE FOREGOING, XANTREX MAKES NO REPRESENTATIONS OR WARRANTIES REGARDING THE USE OF THE XANTREX C12 IN CONNECTION WITH LIFE SUPPORT SYSTEMS OR OTHER MEDICAL EQUIPMENT OR DEVICES.

Return Material Authorization Policy

Before returning a product directly to Xantrex you must obtain a Return Material Authorization (RMA) number and the correct factory "Ship To" address. Products must also be shipped prepaid. Product shipments will be refused and returned at your expense if they are unauthorized, returned without an RMA number clearly marked on the outside of the shipping box, if they are shipped collect, or if they are shipped to the wrong location.

When you contact Xantrex to obtain service, please have your instruction manual ready for reference and be prepared to supply:

- The serial number of your product
- Information about the installation and use of the unit
- Information about the failure and/or reason for the return
- A copy of your dated proof of purchase

Return Procedure

1. Package the unit safely, preferably using the original box and packing materials. Please ensure that your product is shipped fully insured in the original packaging or equivalent. This warranty will not apply where the product is damaged due to improper packaging.
2. Include the following:
 - The RMA number supplied by Xantrex Technology, Inc. clearly marked on the outside of the box.
 - A return address where the unit can be shipped. Post office boxes are not acceptable.
 - A contact telephone number where you can be reached during work hours.
 - A brief description of the problem.
3. Ship the unit prepaid to the address provided by your Xantrex customer service representative.

If you are returning a product from outside of the USA or Canada In addition to the above, you MUST include return freight funds and are fully responsible for all documents, duties, tariffs, and deposits.

If you are returning a product to a Xantrex Authorized Service Center (ASC) A Xantrex return material authorization (RMA) number is not required. However, you must contact the ASC prior to returning the product or presenting the unit to verify any return procedures that may apply to that particular facility.

Out of Warranty Service

If the warranty period for your Xantrex C12 has expired, if the unit was damaged by misuse or incorrect installation, if other conditions of the warranty have not been met, or if no dated proof of purchase is available, your product may be serviced or replaced for a flat fee.

To return your Xantrex C12 for out of warranty service, contact Xantrex Customer Service for a Return Material Authorization (RMA) number and follow the other steps outlined in "Return Procedure".

Payment options such as credit card or money order will be explained by the Customer Service Representative. In cases where the minimum flat fee does not apply, as with incomplete units or units with excessive damage, an additional fee will be charged. If applicable, you will be contacted by Customer Service once your unit has been received.